



Service Bulletin Number	Date
4383774	27-JAN-2015



Service Bulletin

ISX15 and QSX15 Piston and Cylinder Liner Change History, Identification and Compatibility

History and Background

This document provides information on piston and cylinder liner identification and compatibility. The ISX/QSX series engines have experienced multiple piston and cylinder liner product improvements since the initial production launch in 1998. Multiple variations and combinations of the cylinder liners and pistons, dependent on engine build date and rebuild history, can result in compatibility issues. Proper identification of components and component compatibilities **must** be completed before ordering parts using this document as a guide.

History of cylinder liner product improvements:

1998 - 2000: Engines produced with groove top cylinder liners

2000 - 2010: Improvement to 150 mm outer diameter flat top cylinder liner with no shim

2010 - 2013: Improvement to 152 mm outer diameter flat top cylinder liner with no shim

2012 - 2015: Improvement to 150 mm outer diameter flat top cylinder liner with a shim

2015 - Current: Improvement to 150 mm outer diameter flat top cylinder liner with a shim and anti-polishing ring (APR)

History of piston product improvements:

Pistons vary by piston skirt design, piston top ring location, and piston top land diameter. Generally, the component progression has been from open skirt to closed skirt design, high piston top ring to low piston top ring location, and non-reduced diameter to reduced diameter top land pistons. The best way to identify the type of piston in an engine is to see the component identification section below.

Product Affected

Table 1, Product Affected		
Engine Model Name	Engine Control System	Identifier

Table 1, Product Affected		
Engine Model Name	Engine Control System	Identifier
ISX	CM570, CM870, CM871, CM871 E, Signature	Not Applicable
ISX15	CM2250, CM2250 SN	Not Applicable
ISX15	CM2350	X101
PowerGen QSX15	CM2250	Not Applicable
	CM2250	ECF
QSX15	CM570, CM870, CM871, CM871 E, Signature	Not Applicable
	CM2250	ECF
QSX15	CM2350	X105, X106

Component Identification

Anti-Polishing Ring Cylinder Liner

Anti-polishing ring cylinder liners can be identified by a removable carbon scraper ring known as the anti-polishing ring in the top of the cylinder liner. The cylinder liner has a counterbore machined into the top of the cylinder liner where the anti-polishing ring installs. The anti-polishing ring overhangs the liner bore allowing carbon to be scrapped from the piston top land which limits carbon thickness. Limiting the carbon thickness prevents carbon contact with the cylinder liner and prevents cylinder liner bore polish.

Anti-polishing ring cylinder liners will have two bands machined around the bottom outer diameter of the cylinder liner. This indicates that the cylinder liner is equipped with an anti-polishing ring and a brass shim. These bands are intended for cylinder liner identification when the cylinder liner is installed in an engine. The bands can be viewed or felt from the bottom of the engine when the lubricating oil pan is removed.

The anti-polishing ring is symmetrical so there is no top or bottom orientation.

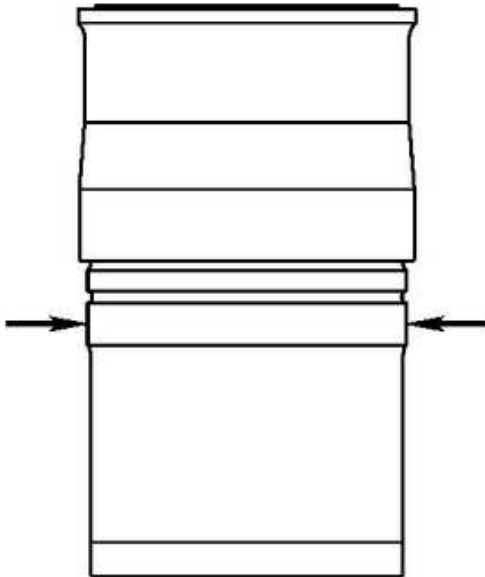

Figure 1, Anti-polishing ring cylinder liner cross-section with low top ring piston and piston rings

Cylinder Liner Mid Stop Diameter Differences

Mid stop liners are available in 150 mm [5.906 in] or 152 mm [5.984 in] outer diameters. Measure the mid stop liner at the location shown in Figure 2 to identify the mid stop cylinder liner size.

©Cummins Inc



01r00029

Figure 2, Measurement location to identify the mid stop cylinder liner dimension

Low Top Ring Pistons vs. High Top Ring Pistons

To identify a low top ring piston, set a piston on a flat surface with the combustion face down. Measure the distance from the combustion face to the start of the top ring groove. The low top ring piston will measure greater than 11 mm [0.433 in]. A high top ring piston will measure approximately 8 mm [0.315 in].

©Cummins Inc



Figure 3, Low top ring piston on the left and a high top ring piston on the right

©Cummins Inc

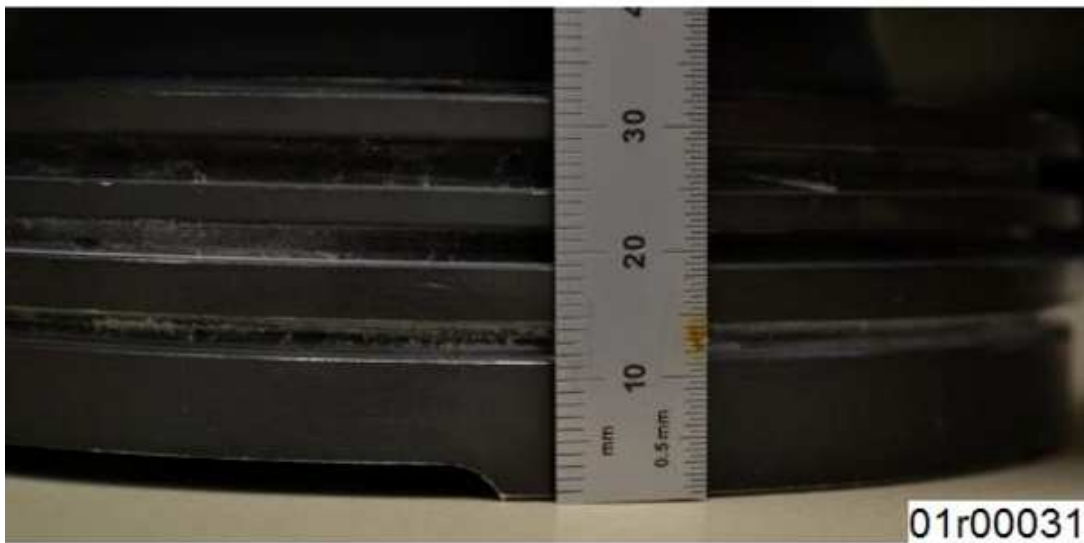

Figure 4, Low top ring piston

Reduced Diameter Top Land Pistons vs. Non-Reduced Diameter Top Land Pistons

To identify a reduced diameter top land piston, measure the diameter of the piston land above the top ring. Reduced diameter top land pistons will measure 134.86 ± 0.05 mm [5.309 ± 0.002 in]. Non-reduced

diameter top land pistons will measure 135.30 +/- 0.05 mm [5.327 +/- 0.002 in.



Figure 5, Measurement location to identify piston top land diameter

Open Skirt Piston vs. Closed Skirt Piston

Use Figure 6 to identify an open skirt piston versus a closed skirt piston.



Figure 6, Closed skirt piston on the left and open skirt piston on the right

Part Compatibility

Cylinder Liners

There are four different cylinder liners available. It is important to identify the cylinder liner being removed to properly select the replacement cylinder liner. For identification using the liners physical characteristics use the information in the component identification section of this documents and Table 2 to select the correct replacement cylinder liner. For cylinder liner and cylinder liner kit part numbers see TSB150069.

NOTE: Mixing of APR cylinder liner with non-APR cylinder liners within an engine is not recommended. The engine should have either all APR cylinder liners or all non-APR cylinder liners at the completion of repair.

Shimmed cylinder liners are backward compatible with all flat top cylinder liners (with or without shims) and can be mixed within an engine.



Engines equipped with a shimmed cylinder liner assembly can **not** be repaired with a non-shimmed cylinder liner.

Existing Engine Configuration	Replacement Cylinder Liner		
	150 mm Non-Anti-Polishing Ring Liner	152 mm Non-Anti-Polishing Ring Liner	150 mm Anti-Polishing Ring Liner
150 mm Non-Anti-Polishing Ring Liner	Individual Cylinder Repairs	Not Compatible	Six Cylinder Upgrade (With low top ring pistons) ¹
152 mm Non-Anti-Polishing Ring Liner	Not Compatible	Direct Replacement	Not Compatible
150 mm Anti-Polishing Ring Liner	Not Compatible	Not Compatible	Direct Replacement

¹ When performing a six cylinder upgrade to anti-polishing ring cylinder liners on engine with high top ring pistons, the pistons **must** be updated to low top ring pistons. High top ring pistons will lead to mechanical interference between the anti-polishing ring and piston top ring. This interference will **not** allow the engine to be reassembled.

Pistons

Pistons can vary by piston skirt design, piston top ring location, and piston top land diameter. All high top ring pistons, whether closed skirt or open skirt, have been superseded to low top ring closed skirt pistons for production engines and 6 cylinder engine upgrades. Engines with high top ring pistons require conversion to low top ring pistons for 6 cylinder engine upgrades and to install anti-polishing ring cylinder liners. Low top ring closed skirt pistons are backwards compatible with all products listed in the Product Affected section that have closed skirt pistons.

CAUTION

Closed skirt pistons are **not** compatible with engines that have open skirt pistons. Engines can **not** have a mix of open skirt and closed skirt pistons due to piston weight. Severe engine damage may occur if open skirt and closed skirt pistons are intermixed.

Open skirt pistons will remain available for single cylinder repairs for engines equipped with open skirt pistons. For six cylinder engine upgrades, upgrade to low top ring, closed skirt pistons which are compatible with anti-polishing ring cylinder liners.

For piston compatibility using piston physical characteristics use Table 3. In Table 3 the left column is a list of the possible combinations of piston characteristics that can be found in an engine. The middle column contains the scenario where an open skirt piston should be used as a replacement for the ones found in the engine. The right column contains the scenarios where closed skirt pistons should be used as a replacements for the pistons found in the engine. For piston part numbers see TSB150069.

Table 3, Piston Compatibility Matrix		
Existing Engine Configuration	Replacement Piston	
	Open Skirt, High Top Ring, Non-Reduced or Reduced Diameter Top Land	Closed Skirt, Low Top Ring, Reduced Diameter Top Land
Open Skirt, High Top Ring, Non-Reduced or Reduced Diameter Top Land	Individual Cylinder Repairs	Six Cylinder Upgrade
Closed Skirt, High Top Ring, Non-Reduced Diameter Top Land	Not Compatible	Single to Six Cylinder Upgrade
Closed Skirt, High Top Ring, Reduced Diameter Top Land	Not Compatible	Single to Six Cylinder Upgrade
Closed Skirt, Low Top Ring, Non-Reduced Diameter Top Land	Not Compatible	Single to Six Cylinder Upgrade
Closed Skirt, Low Top Ring, Reduced Diameter Top Land	Not Compatible	Direct Replacement

Document History

Date	Details
2015-1-27	Module Created
2015-4-16	Added product affected table, corrected Cylinder Liner Compatibility Matrix, added Table 4, updated Piston Compatibility Matrix.
2015-5-13	Moved some content to TSB150069.

Last Modified: 28-May-2015

Copyright © 2000-2010 Cummins Inc. All rights reserved.