



# Technical Service Bulletin

Technical Service Bulletin: TSB190018	Released Date: 25-Mar-2019
Lubricating Oil Pumps with Unexpected Oil Pressures	

## Lubricating Oil Pumps with Unexpected Oil Pressures

### Warranty Statement

The information in this document has no effect on present warranty coverage or repair practices, nor does it authorize TRP or Campaign actions.

### Contents

#### Product Affected

- ISX CM570
- ISX CM870
- ISX CM871
- ISX CM871 E
- ISX15 CM2250
- ISX15 CM2250 SN
- ISX15 CM2350 X101
- QSX15 CM2250
- QSX15 CM2250 ECF
- QSX15 CM2250 X115
- QSX15 CM2350 X105
- QSX15 CM2350 X106
- QSX15 CM570
- QSX15 CM2350 X118
- X15 CM2350 X116B

#### Issue

##### Symptom:

- Unexpectedly high or low oil pressures that do **not** generate one of the following fault codes:
  - FC415
  - FC435
  - FC143

##### Root Cause:

- A new lubricating oil pump was released to production with different flow characteristics that do **not** affect function of the lubricating oil system.

### Verification

Lubricating oil pressures may be  $\pm 41$  kPa [ 6 psi ] different than expected during normal operating conditions. Determine if any oil pressure related fault codes are being generated.

### Resolution

If no fault codes are generated no action is required. If a fault code is generated follow the normal fault code troubleshooting tree.

### Reason for Change

A new cast iron lubricating oil pump, Part Number 5532492, was released to replace an existing aluminum lubricating oil pump, Part Number 3687527, and cast iron lubricating oil pump Part Number 3687528, for some 15L engines. New Part Number 5532492 has different flow characteristics that do **not** affect lubricating oil system function, but can result in different oil pressure values than expected. Part Number 5532492 does **not** use shims to set gear lash like existing lubricating oil pump Part Numbers 3687528 and 3687527.

### Part Compatibility

New lubricating oil pump is backwards compatible, and interchangeable on engines using existing lubricating oil pumps. New pump does **not** use shims to set gear lash. For instructions on measuring and setting gear lash, see corresponding Service Manuals. Reference section 007-031.

### Part Identification

Lubricating oil pumps can be identified by the style of the regulator plug on the bottom of the lube pump. The new pump has a threaded plug. Existing pumps have a pinned plug. Pumps can also be distinguished by part numbers on the pump housings. See Figures 1 and 2 below.

©Cummins Inc

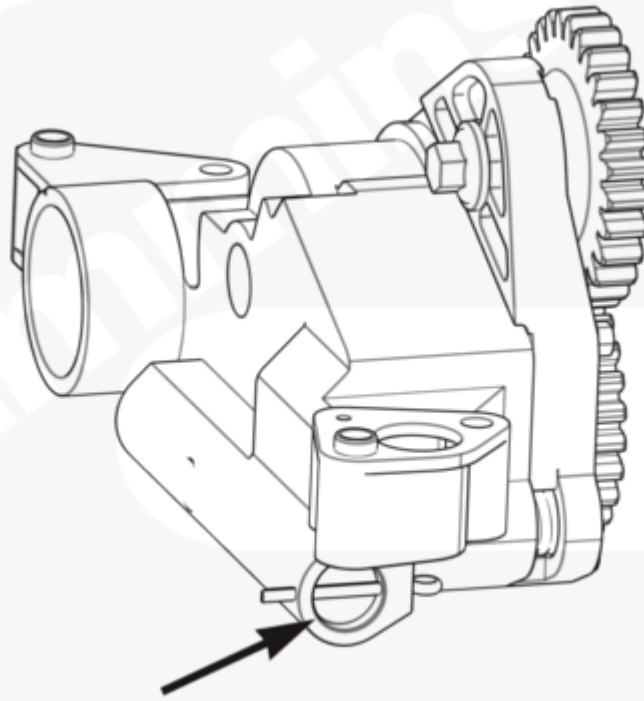

07y00022

Figure 1, Existing Lubricating Oil Pump with Pinned Regulator Plug.

©Cummins Inc

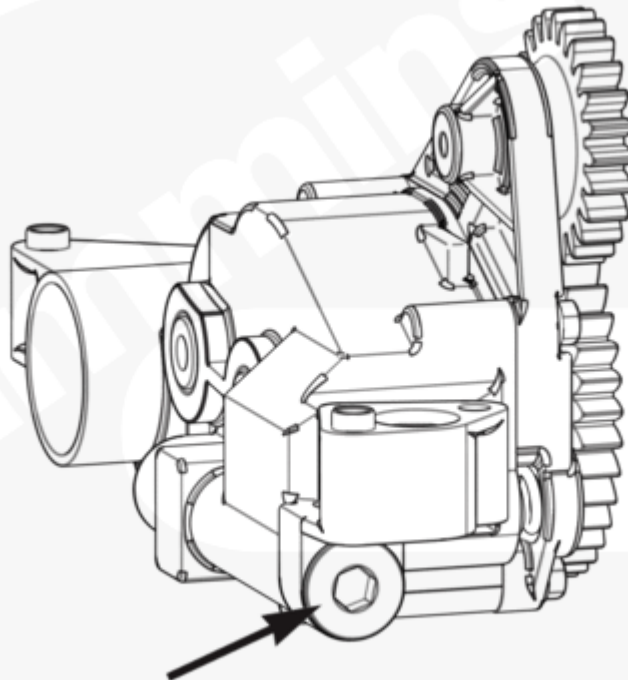

07y00021

Figure 2, New Lubricating Oil Pump with Threaded Regulator Plug.

**Production Status**

<b>Table 1, Production Information</b>		
<b>ESN First</b>	<b>Build Date<sup>1</sup></b>	<b>Plant</b>
80137579	14 January 2019	Jamestown Engine Plant
<sup>1</sup> Engine build date can be found on engine dataplate.		

### Publications Affected

<b>Table 2, Updated Service Procedures</b>					
<b>Manual Type</b>	<b>Description</b>	<b>Bulletin Number</b>	<b>Procedure Title</b>	<b>Procedure</b>	<b>Section</b>
Service Manual	Signature, ISX and QSX15	3666239	Lubricating Oil Pump	Refer to Procedure 007-031	7
	ISX15 CM2250	4022250			
	QSX15 CM2250	2883557			
	ISX15 CM2350 X101	4310641			
	Power Gen QSX15 CM2250 ECF	4310661			
	Power Gen QSX15 CM2250	4310664			
	ISX15 CM2250 SN	4310736			
	QSX15 CM2350 X105	4332667			
	QSX15 CM2350 X106	4332712			
	QSX15 CM2250 X115	4388739			
	X15 CM2350 X116B	5411186			

<b>Table 2, Updated Service Procedures</b>					
<b>Manual Type</b>	<b>Description</b>	<b>Bulletin Number</b>	<b>Procedure Title</b>	<b>Procedure</b>	<b>Section</b>
	QSX15 CM2350 X118	5467247			
	QSX15 CM2350 X118	5467249			

<b>Table 3, Updated Lubricating Oil System Specifications</b>			
<b>Manual Type</b>	<b>Description</b>	<b>Bulletin Number</b>	<b>Procedure</b>
Service Manual	Signature, ISX and QSX15	3666239	018-017
	ISX15 CM2250	4022250	
	QSX15 CM2250	2883557	
	ISX15 CM2350 X101	4310641	
	Power Gen QSX15 CM2250 ECF	4310661	
	Power Gen QSX15 CM2250	4310664	
	ISX15 CM2250 SN	4310736	
	QSX15 CM2350 X105	4332667	
	QSX15 CM2350 X106	4332712	
	QSX15 CM2250 X115	4388739	
	X15 CM2350 X116B	5411186	
	QSX15 CM2350 X118	5467247	
	QSX15 CM2250 ECF	2883560	
Operations and Maintenance Manual	Signature™/ISX	3666251	
	ISX15 CM2250	2883361	
	QSX15 Industrial and Power Generation	3666423	
	ISX15 CM2350 X101	4310640	

<b>Table 3, Updated Lubricating Oil System Specifications</b>			
<b>Manual Type</b>	<b>Description</b>	<b>Bulletin Number</b>	<b>Procedure</b>
	PowerGen QSX15 CM2250 ECF	4310663	
	PowerGen QSX15 CM2250	4310666	
	ISX15 CM2250 SN	4310735	
	QSX15 CM2350 X105	4332668	
	QSX15 CM2350 X106	4332713	
	QSX15 CM2250 X115	4388740	
	X15 CM2350 X116B - Performance Series	5411187	
	QSX15 CM2350 X118	5467248	
	QSX15 CM2250 ECF	2883559	
Owner's Manual	Signature™/ISX	4960314	
	ISX15 CM2250	2883360	
	QSX15 Industrial and Power Generation	4915540	
	ISX15 CM2350 X101	4310639	
	PowerGen QSX15 CM2250 ECF	4310662	
	PowerGen QSX15 CM2250	4310665	
	ISX15 CM2250 SN	4310734	
	QSX15 CM2350 X105	4332669	
	QSX15 CM2350 X106	4332714	
	QSX15 CM2250 X115	4388741	
	X15 CM2350 X114B - Efficiency Series, X15 CM2350 X116B - Performance Series	5411183	

<b>Table 3, Updated Lubricating Oil System Specifications</b>			
<b>Manual Type</b>	<b>Description</b>	<b>Bulletin Number</b>	<b>Procedure</b>
	QSX15 CM2350 X118	5467249	

## Document History

<b>Date</b>	<b>Details</b>
2019-1-24	Module Created
2019-1-29	correct outfile
2019-2-4	Added Verification and Resolution Sections
2019-3-25	Added ISX CM870

---

**Last Modified: 25-Mar-2019**

---